

Model PRV-1 Pressure Reducing Valve Pilot Operated, Globe and Angle Body Styles

General Description

The TYCO Model PRV-1 Pressure Reducing Valves, 2 through 8 in. (DN50 through DN200), are factory-assembled and fully trimmed valve arrangements for pressure control. They are used on water filled pipe where it is necessary to reduce a higher inlet pressure to a lower delivery pressure under static and/or residual flowing conditions. The Model PRV-1 Valve is intended to automatically maintain the outlet "set pressure" (static and residual) within a close range, regardless of fluctuations in the higher pressure inlet line or varying flow rates.

The Model PRV-1 Valve is provided with a factory outlet "set pressure" of 125 psi (8,6 bar); however, it may be field set to a nominal outlet "set pressure" of 80 to 225 psi (5,5 to 15,5 bar) per its FM Approval or 80 to 150 psi (5,5 to 10,3 bar) per its UL Listing.

Typical applications

- Within the main header (Ref. Figure 1) supplying wet pipe, dry pipe, deluge, or preaction system risers, and/or a standpipe system supplying hose connections
- As part of a sectional floor control assembly (Ref. Figure 2) supplying sprinkler systems, and/or hose stations

Features

- Can be installed in vertical or horizontal orientation
- Eliminates any required bleeding of trapped air from the diaphragm chamber during installation
- Globe or angle pattern
- Accurate pressure control
- RILSAN Red coated internal and external
- One piece, one moving part diaphragm
- In-line service

- One pilot valve sub-assembly provides for any outlet "set pressure", that is, 80 to 225 psi (5,5 to 15,5 bar)

NOTICE

The TYCO Model PRV-1 Pressure Reducing Valves described herein must be installed and maintained in compliance with this document and with the applicable standards of the National Fire Protection Association (NFPA), in addition to the standards of any authorities having jurisdiction. Failure to do so may impair the performance of these devices.

Owners are responsible for maintaining their fire protection system and devices in proper operating condition. Contact the installing contractor or sprinkler manufacturer with any questions.

Due to the flow regulating characteristic of this device, its impact on system hydraulics should be carefully considered, especially when retrofitted into existing systems.

WARNING

Adjustment of the Needle Valve is factory set and must not be altered.

Technical Data

Approvals

UL and C-UL Listed
FM Approved

The UL Listing is based on:

- Installation requirements referenced in the Standard for Installation of Sprinkler Systems, NFPA 13, or the Standard for Installation of Standpipe and Hose Valves, NFPA 14, as applicable.
- Inspection, testing, and maintenance requirements referenced in the Standard for Inspection, Testing, and Maintenance of Water-Based Fire Protection Systems, NFPA 25.
- Filed-setting of the Model PRV-1 Valve to provide required outlet pressures and flows for the given application.



- Testing of the Model PRV-1 Valve after installation in accordance with NFPA 13 and/or NFPA 14 as applicable.
- Testing the Model PRV-1 Valve tested periodically thereafter in accordance with NFPA 25.

Maximum Inlet Pressure

250 psi (17,2 bar)

Factory Outlet "Set Pressure"

125 psi (8,6 bar)

Field Outlet "Set Pressure" Range

80 to 225 psi (5,5 to 15,5 bar) per FM Approval, or 80 to 150 psi (5,5 to 10,3 bar) per UL Listing

Pressure Loss With Inlet Pressure Above "Set Pressure"

The inlet pressure minus the outlet "set pressure" equals pressure loss. For example, assuming that the inlet flowing pressure is 225 psi (15,5 bar) and the field outlet "set pressure" is 130 psi (9,0 bar), the pressure loss is 95 psi (6,5 bar).

Pressure Loss with Inlet Pressure Below “Set Pressure”

Refer to Graphs A through E. These graphs are a requirement of UL and should be used as reference only.

Rated Flowing Range

2 in.	0 to 250 GPM
(DN50)	(0 to 946 LPM)
3 in.	0 to 550 GPM
(DN80)	(0 to 2080 LPM)
4 in.	0 to 1000 GPM
(DN100)	(0 to 3785 LPM)
6 in.	0 to 2200 GPM
(DN150)	(0 to 8325 LPM)
8 in.	0 to 4000 GPM
(DN200)	(0 to 15140 LPM)

End Connections

- Threaded end connections are available as NPT threaded or threaded per ISO 7-1.
- Flanged end connections are available as drilled per Table C.
- Grooved end connections follow industry standard groove specifications.

Materials of Construction

(Refer to Figure 3)

- The Body is RILSAN polyamide 11 coated, ductile iron per ASTM A 536-77, Grade 65-45-12.
- The Diaphragm Cover is RILSAN polyamide 11 coated, ductile iron per ASTM A 536-77, Grade 65-45-12.
- The Diaphragm is nylon fabric-reinforced, natural rubber per ASTM D2000. Diaphragm Cover Fasteners are galvanized carbon steel.
- The Pilot Valve is brass and stainless steel with nylon fabric-reinforced, natural rubber per ASTM D 2000 diaphragm.
- The Strainer is brass and stainless steel.
- Pressure Gauges have a 2 1/2 in. (65 mm) diameter, stainless steel case, and 0 to 350 psi (0 to 25 bar) pressure rating.
- Tube, Fittings, and Needle Valve are copper, brass, and stainless steel.

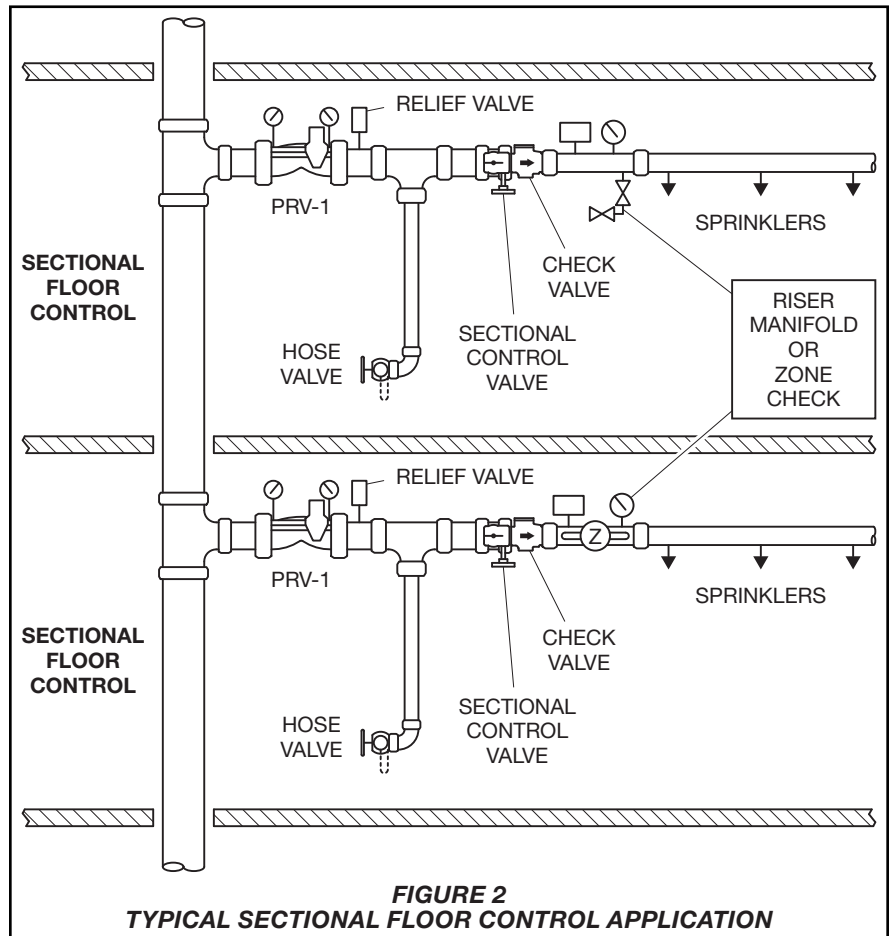
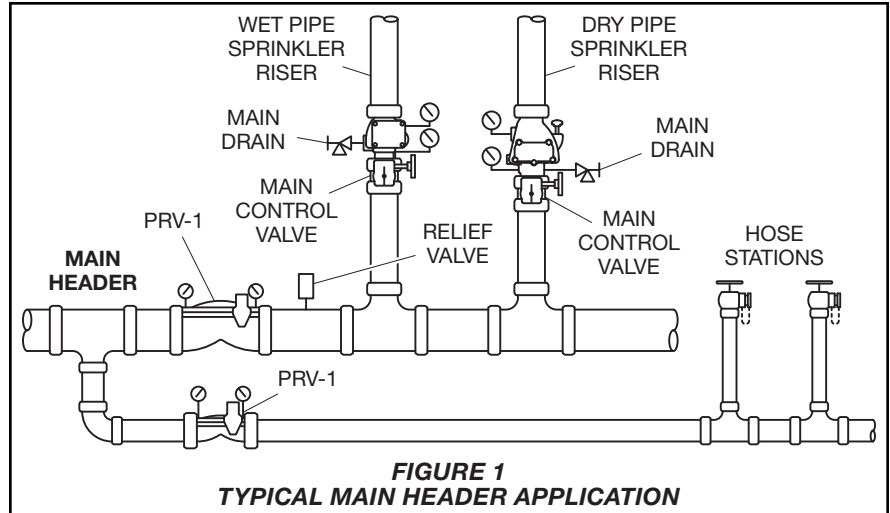

Body Style	End Connection	Nominal Valve Size				
		2 in. (DN50)	3 in. (DN80)	4 in. (DN100)	6 in. (DN150)	8 in. (DN200)
Globe	Thread x Thread	✓	N/A	N/A	N/A	N/A
	Groove x Groove	✓	✓	✓	✓	✓
	Flange x Flange	N/A	N/A	✓	✓	✓

- NOTES:**
- ✓ = Available
 - N/A = Not Available

TABLE A
AVAILABLE SIZES AND CONFIGURATIONS
NORTH AMERICA

Body Style	End Connection	Nominal Valve Size				
		2 in. (DN50)	3 in. (DN80)	4 in. (DN100)	6 in. (DN150)	8 in. (DN200)
Globe	Thread x Thread	✓	✓	N/A	N/A	N/A
	Groove x Groove	✓	✓	✓	✓	N/A
	Flange x Flange	N/A	✓	✓	✓	✓
Angle	Thread x Thread	✓	✓	N/A	N/A	N/A
	Groove x Groove	✓	✓	✓	✓	N/A
	Flange x Flange	N/A	✓	✓	✓	N/A

- NOTES:**
- ✓ = Available
 - N/A = Not Available

TABLE B
AVAILABLE SIZES AND CONFIGURATIONS
SOUTH AND CENTRAL AMERICA AND EASTERN HEMISPHERE

Nominal Valve Size Inches (DN)	Flange Drilling Specification															
	Nominal Installation Dimensions in. (mm)															
	ANSI B16.11 ^a (Class 125)			ISO 7005-2 (PN10) ^{2b}			ISO 7005-2 (PN16) ^{3c}			JIS B 2210 (10K)			AS 2129 (Table E)			
	A	B	N	A	B	N	A	B	N	A	B	N	A	B	N	
3 (DN80)	6.00 (152,4)	0.75 (19,0)	4	USE ISO 7005-2 (PN16)			6.30 (160,0)	0.75 (19,0)	8	5.90 (150,0)	0.59 (15,0)	8	5.75 (146,0)	0.71 (18,0)	4	
4 (DN100)	7.50 (190,5)	0.75 (19,0)	8				7.09 (180,0)	0.75 (19,0)	8	6.89 (175,0)	0.60 (15,0)	8	7.00 (178,0)	0.71 (18,0)	8	
6 (DN150)	9.50 (241,3)	0.88 (22,2)	8				9.45 (240,0)	0.91 (23,0)	8	9.45 (240,0)	0.75 (19,0)	8	9.25 (235)	0.87 (22,0)	8	
8 (DN200)	11.75 (298,5)	0.88 (22,2)	8	11.61 (295,0)	0.91 (23,0)	8	11.61 (295,0)	0.91 (23,0)	12	11.42 (290,0)	0.75 (19,0)	12	11.50 (292,0)	0.87 (22,0)	8	

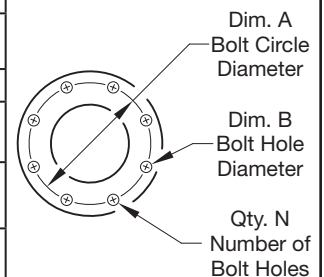

- NOTES:**
- Same drilling as for ANSI B16.5 (Class 150) and ANSI B16.42 (Class 150)
 - Same drilling as for BS 4504 Section 3.2 (PN10) and DIN 2532 (PN10)
 - Same drilling as for BS 4504 Section 3.2 (PN16) and DIN 2532 (PN16)

TABLE C
DIMENSIONAL SPECIFICATION FOR SELECTION OF FLANGE DRILLING

VALVE PARTS		
NO.	DESCRIPTION	QTY. KIT
1	Valve Body	1 NR
2	Diaphragm	1 (a)
3	Diaphragm Cover	1 NR
4	Flat Washer,	
	2 Inch Valve, M12	4 CH
	3 & 4 Inch Valves, M16	4 CH
	6 & 8 Inch Valves, M16	8 CH
5	Hex Bolt,	
	2 Inch Valve, M12 x 35	4 CH
	3 & 4 Inch Valves,	
	M16 x 55	4 CH
	6 Inch Valve, M16 x 45	8 CH
	8 Inch Valve, M16 x 55	8 CH
6	Hex Nut, M16,	
	4 Inch Valve Only	4 CH
7	Pilot Valve	1 (b)
8	Water Pressure Gauge	2 (c)
9	Strainer	1 (d)
10	Pressure Sensor Insert	1 (e)
11	Tubing and Fittings	1 (f)
12	Needle Valve	1 (g)

REPLACEMENT PART KITS		
KIT	DESCRIPTION	P/N
(a)	Diaphragm, Fits Either Body Style, Includes Item 2 only:	
	2 Inch Valves	92-570-2-011
	3 Inch Valves	92-570-2-012
	4 Inch Valves	92-570-2-013
	6 Inch Valves	92-570-2-014
	8 Inch Valves	92-570-2-015
(b)	Pilot Valve	92-570-2-200
(c)	Water Pressure Gauge	92-570-2-211
(d)	Strainer:	
	2, 3, & 4 Inch Valves	92-570-2-202
	6 & 8 Inch Valves	92-570-2-209
(e)	Pressure Sensor Insert:	
	2 Inch Valve	92-570-2-203
	3 Inch Valve	92-570-2-204
	4 Inch Valve	92-570-2-205
	6 Inch Valve	92-570-2-206
	8 Inch Valve	92-570-2-207
(f)	Tubing and Fitting Kit, Excludes Items 7, 8, 9, 10 and 12	
	Globe Style Valve:	
	2 Inch Valve	92-570-3-001
	3 Inch Valve	92-570-3-002
	4 Inch Valve	92-570-3-003
	6 Inch Valve	92-570-3-004
	8 Inch Valve	92-570-3-005
	Angle Style Valve:	
	2 Inch Valve	92-571-3-001
	3 Inch Valve	92-571-3-002
	4 Inch Valve	92-571-3-003
	6 Inch Valve	92-571-3-004
(g)	Needle Valve	92-570-2-212

NOTES:
 1. NR - Not Replaceable
 2. CH - Common Hardware
 3. Install Item 8 in field

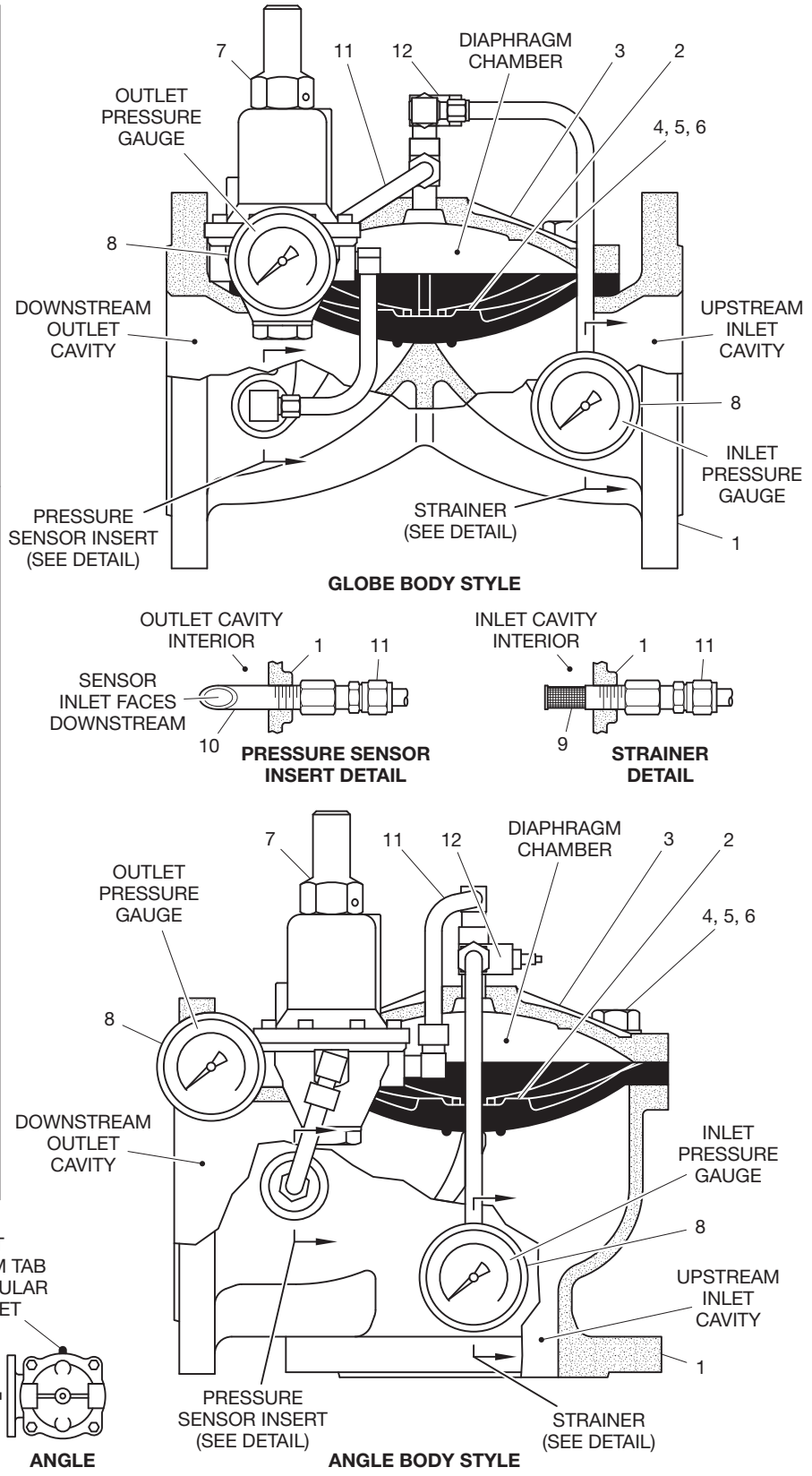
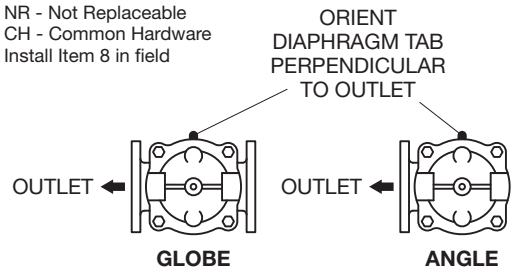
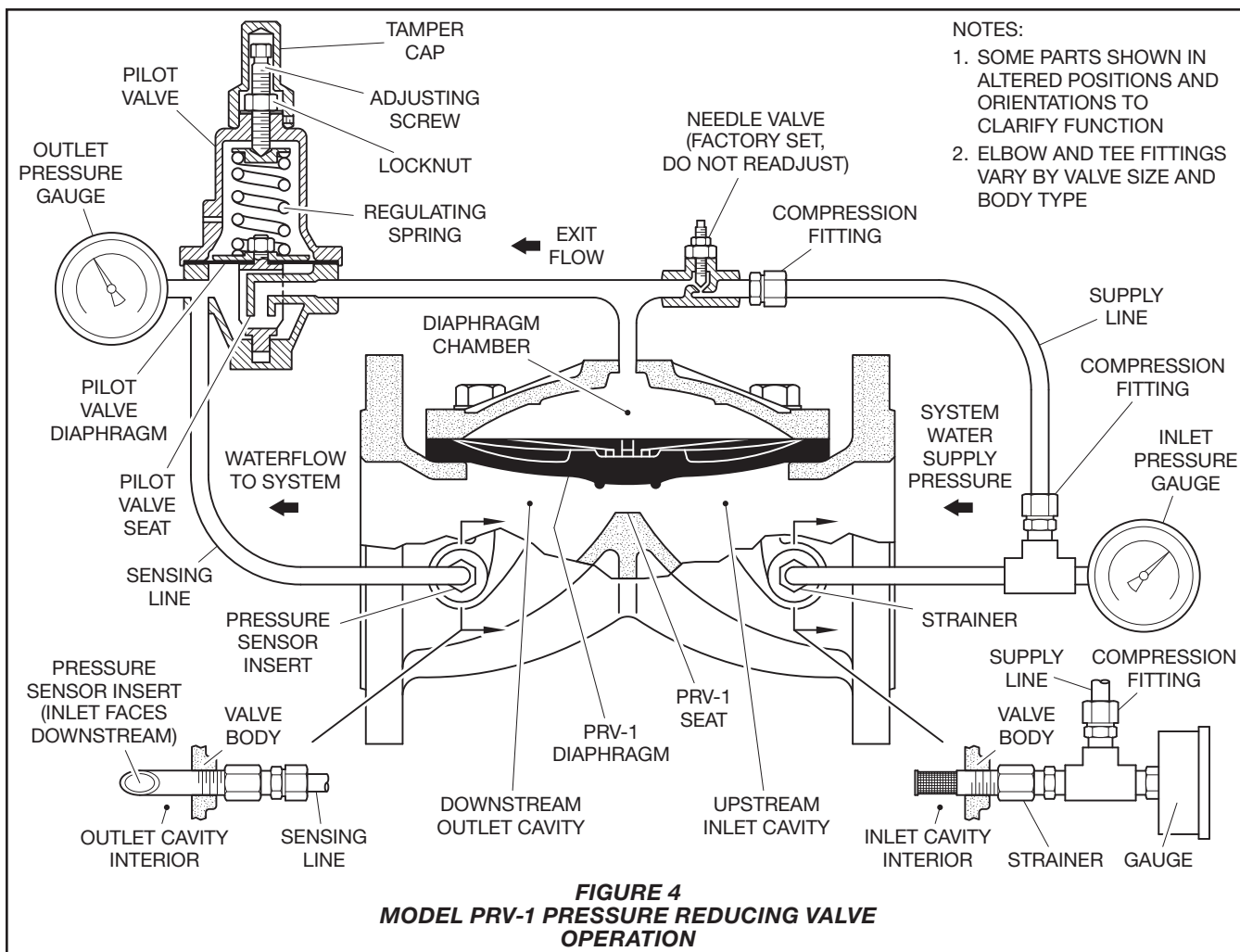

FIGURE 3
MODEL PRV-1 PRESSURE REDUCING VALVE ASSEMBLY



Operation

With reference to Figure 4, the system water supply pressure from the inlet cavity of the Model PRV-1 Valve enters the Diaphragm Chamber through a Strainer and Needle Valve. The factory set Needle Valve provides the required orifice size for the supply line to the Diaphragm Chamber to optimize performance.

Exit flow from the Diaphragm Chamber through the Pilot Valve is controlled by a regulating spring that is factory set, and subsequently field adjustable, to the desired downstream “set pressure” that is to be maintained. A sensing line connects the outlet of the Pilot Valve to the system piping downstream of the Model PRV-1 Valve via the Pressure Sensor Insert in the outlet cavity.

When the downstream pressure rises above the “set pressure” of the spring, exit flow from the Diaphragm Chamber through the Pilot Valve to the Model PRV-1 Valve outlet cavity is stopped and pressure increases in the Diaphragm Chamber. When downstream

pressure falls below the “set pressure” of the spring, exit flow from the Diaphragm Chamber through the Pilot Valve to the Model PRV-1 Valve outlet cavity resumes and pressure in the Diaphragm Chamber decreases.

The regulated flow through the Pilot Valve decreases and increases the pressure in the diaphragm chamber to sufficiently open and close the Model PRV-1 Valve, as required, to regulate the downstream “set pressure”.

The operation sequence is as follows:

- When there is no flow demand downstream of the Model PRV-1 Valve, the Seat is closed and the Pilot Valve Seat is closed. With the Pilot Valve Seat closed, pressure is trapped in the Diaphragm Chamber to seat the Diaphragm and the Model PRV-1 Valve remains closed.
- When there is a flow demand downstream of the Model PRV-1 Valve and the outlet pressure drops below the “set pressure”, the Pilot Valve Seat opens to relieve pressure from the Diaphragm Chamber allowing the Model PRV-1 Valve to open.

- As the flow demand continues downstream of the Model PRV-1 Valve and the “set pressure” is met, the Pilot Valve Seat closes. As the Pilot Valve Seat closes to reduce the opening, pressure is trapped in the Diaphragm Chamber at a point that allows the Diaphragm to remain lifted from the Model PRV-1 Valve Seat to retain the downstream “set pressure”.
- Should the downstream pressure start to fall below the “set pressure”, the Pilot Valve Seat re-opens to allow for a decrease in pressure in the Diaphragm Chamber to allow the Model PRV-1 Valve to open further and then once again establish the downstream “set pressure”.
- When the downstream pressure is at or above the “set pressure” and assuming there is a flow demand downstream of the Model PRV-1 Valve, the Pilot Valve Seat is closed to trap a sufficient pressure in the Diaphragm Chamber to allow the Model PRV-1 Valve to remain open to provide the “set pressure”.

Design Considerations

The following items must be considered and applied accordingly for an installation that will be using the Model PRV-1 Pressure Reducing Valve:

- The Model PRV-1 Valve may be installed vertically or horizontally and in any orientation without affecting its operating efficiency. When planning the positioning of the Model PRV-1 Valve, it is recommended that consideration be given to the viewing of the pressure gauges. Consideration should also be given to positioning the Model PRV-1 Valve so that the diaphragm cover is facing up. With the cover facing up, internal access is more easily achieved.
- The Model PRV-1 Valve must be in an area that is easily accessible for maintenance purposes, not subject to freezing temperatures, and not subject to physical damage.
- The valve is designed for fresh water service. When corrosive atmospheres and/or contaminated water supplies are present, it is the owner's responsibility to verify compatibility with the pressure reducing valve, pilot valve, and trim.
- The difference between the water supply pressure and the desired outlet (downstream) pressure must be 25 psi (1,7 bar) or greater per its FM Approval or 50 psi (3,4 bar) or greater per its UL Listing. The differential maintains accuracy control of the discharging pressure over the full rated flowing range.
- Cavitation may occur when the inlet pressure is greater than twice the "set pressure". For this case, the pressure should be reduced in two steps by using two Model PRV-1 Valves in series.
- When reducing pressure for a sprinkler system, a ½ in. (DN15) or larger relief valve shall be located downstream of the Model PRV-1 Valve. The relief valve shall be set at a pressure equal to the lowest pressure rated component downstream of the Model PRV-1 Valve.

Note: FM Approval is based on the use of the 1/2 in. Watts Regulator, Series 530C Pressure Relief Valve.

- When reducing pressure for a sprinkler system, a listed indicating valve shall be provided on the inlet side of the Model PRV-1 Valve.

- When reducing pressure for a sprinkler system, means shall be provided downstream of the Model PRV-1 Valve to facilitate a flow test at the sprinkler system demand.

Installation

The TYCO Model PRV-1 Pressure Reducing Valve must be installed with the flow arrow located on the Diaphragm Cover pointing in the intended direction of flow. Installation dimensions are provided in Figures 5 and 6.

Before the Model PRV-1 Valve is installed, pipe lines should be flushed of all chips, scale and foreign matter. Care must be exercised to assure that the trim is not damaged during installation.

NOTICE

Do not lift the valve by its trim. Otherwise, the trim may be damaged and impair system operation. The inlet and outlet connections must be made based on the direction of flow arrow provided on the Diaphragm Cover. The valve cannot operate if connected backwards.

Do not alter the trim. Altering the trim may render the valve ineffective and impair the system operation.

Placing the Valve in Service

Perform the following 13 Steps when placing the TYCO Model PRV-1 Pressure Reducing Valve in service.

WARNING

Downstream pressure adjustment is only to be performed by experienced personnel who understand the impact of adjusting the downstream pressure and who take full responsibility of the readjustment from the factory setting. The Pilot Valve is provided with a Tamper Cap, which upon removal will allow for field adjustment by using the Adjusting Screw.

Adjustment of the Needle Valve is factory set and must not be altered.

Per the requirements of NFPA 13, a means shall be provided downstream of the Model PRV-1 Valve to simulate the sprinkler system demand. In the case of hose stations, the opening of a hose valve or multiple hose valves, as required, will be necessary to simulate hose stream demand.

For the purposes of the following instruction, the opening of a "flow test valve" simulates either the sprinkler demand or hose stream demand,

as applicable. The sprinkler demand or hose stream demand must be at least 50 GPM (190 LPM) for 2 to 6 in. (DN50 to DN150) valves and at least 100 GPM (380 LPM) for 8 in. (DN200) valves.

There is no need to vent any trapped air from the Diaphragm Chamber.

Filling the System

Step 1. Install gauges at the Pilot Valve and inlet Sensing Line. Apply thread-sealant to the male end of the threads. Ensure the pips on the pressure gauges are in the upright position.

Step 2. Verify that downstream drain valves are closed and that there are no leaks.

Step 3. Partially open a valve or valves at the end of the system (such as, an inspector's test connection on a wet pipe system) to allow trapped air to escape when filling the system.

Step 4. Slowly and partially open the water supply control valve feeding the Model PRV-1 Valve.

Step 5. After the system fills with water, close the valve or valves that had been partially opened in Step 2.

Step 6. Completely open the main water supply control valve feeding the Model PRV-1 Valve.

Adjusting Downstream Pressure

NOTICE

After any downstream pressure adjustment, the following items are to be recorded on a tag attached to the valve:

- Valve installation location
- Inlet static pressure
- Outlet static pressure
- Inlet residual pressure
- Outlet residual pressure
- Intended outlet flow

The tag is not to be removed until after the system has been accepted by the authority having jurisdiction. It is recommended that the tag not be removed even after acceptance by the authority having jurisdiction unless another means of record keeping is maintained.

Step 1. Remove the Tamper Cap from the Pilot Valve by first loosening its set screw and then unscrewing the Tamper Cap.

Step 2. Open the "flow test valve" to simulate either the desired sprinkler demand or hose stream demand.

Step 3. If surging flow occurs, attempt to bleed trapped air from the system via the inspector's test valve and any other valve that can vent trapped air.

Step 4. Loosen the locknut on the adjusting screw of the Pilot Valve.

Step 5. Turn the adjusting screw clockwise to increase outlet pressure or counterclockwise to decrease outlet pressure.

Step 6. After achieving the desired performance, tighten the locknut on the adjusting screw.

Step 7. Close the “flow test valve”. Observe the outlet pressure gauge and compare to the required “set pressure”. If the required “set pressure” is not achieved, repeat Step 2 and proceed accordingly.

Replace the Tamper Cap and tighten its set screw.

The pressure reducing valve is now set for service.

Due to the spring tolerance within the Pilot Valve, it may be necessary to alternate back and forth between residual and static conditions to achieve the desired “set pressure” for both residual and static conditions.

Care and Maintenance

The TYCO Model PRV-1 Pressure Reducing Valve must be maintained and serviced in accordance with this section.

Before closing a fire protection system main control valve for maintenance work on the fire protection system that it controls, obtain permission to shut down the affected fire protection system from the proper authorities and notify all personnel who may be affected by this action.

NOTICE

Inspection, testing, and maintenance must be performed in accordance with the requirements of the NFPA, and any impairment must be immediately corrected.

Responsibility lies with sprinkler owners for the inspection, testing, and maintenance of their fire protection system and devices in compliance with this document, as well as with the applicable standards of the NFPA (for example, NFPA 25), in addition to the standards of any other authorities having jurisdiction. Contact the installing contractor or product manufacturer with any questions.

Automatic sprinkler systems are recommended to be inspected, tested, and maintained by a qualified Inspection Service in accordance with local requirements and/or national code.

The Model PRV-1 Pressure Reducing Valve requires no lubrication, packing or preventative maintenance; however, replacement of the diaphragm every five years is recommended.

Flow Tests

Flow tests per NFPA are required every five years, at which point the outlet pressure is compared to previous tests. If necessary the Model PRV-1 Valve can be readjusted following the Placing the Valve in Service section. If the desired pressure cannot be achieved, the Diaphragm and/or Pilot Valve should be replaced.

Diaphragm Replacement

Prior to replacing the Diaphragm, the Model PRV-1 Valve must be taken out of service and completely drained. With reference to Figure 3, the Diaphragm Tab is oriented perpendicular to the outlet flow. When reinstalling the Diaphragm Cover, the Diaphragm Cover Fasteners must be uniformly and securely tightened using a cross-draw sequence. After tightening, double check to make certain that all of the Diaphragm Cover fasteners are securely tightened.

Pilot Valve Replacement

Prior to removing the Pilot Valve, the Model PRV-1 Valve must be taken out of service and completely drained. When installing the replacement Pilot Valve, the trim components must be replaced exactly as they were. After reinstalling the Pilot Valve and before returning the Model PRV-1 Valve into service, completely unscrew the Adjusting Screw of the replacement Pilot Valve so as to obtain a minimum outlet “set pressure”. Then proceed to use the instructions under Placing The Valve In Service section to place the Model PRV-1 Valve in service.

NOTICE

The Pilot Valve is not field repairable. Attempting to repair the Pilot Valve may render the valve ineffective and impair the system operation.

Completely unscrewing the Adjusting Screw of the replacement Pilot Valve will help to avoid an accidental over pressurization of the system piping prior to achieving the desired “set pressure”.

Strainer Maintenance

Prior to performing strainer maintenance, the Model PRV-1 Valve must be taken out of service and completely drained. Be prepared for small amounts of residual liquid when disconnecting any trim part. Refer to Figure 4 to identify parts and key features.

Step 1. Loosen compression fitting on supply line at needle valve inlet trim.

Step 2. Disconnect compression fitting on supply line at strainer outlet and swing supply line away for access.

Step 3. Remove inlet pressure gauge and trim as sub-assembly from strainer outlet.

Note: *When removing, do not grip gauge itself, loosen sub-assembly by wrench on fitting closest to strainer only.*

Step 4. Remove strainer from valve body.

Step 5. Disassemble strainer for cleaning. Remove end lock washer and slide screen off strainer body. Clean screen and body.

Step 6. Reassemble screen onto body and secure with lock washer.

Note: *Prior to installing strainer and gauge and trim sub-assembly, clean all exposed male NPT pipe threads and apply TEFLON pipe thread sealant as required. Do not apply sealant to male threads of separated compression fitting. Do not contaminate strainer screen.*

Step 7. Install strainer into valve body. Install gauge and trim sub-assembly into strainer outlet.

Step 8. Reconnect supply line compression fitting to strainer outlet trim and tighten compression fitting on supply line at needle valve inlet trim.

Refer to Placing the Valve in Service section to place the Model PRV-1 Valve in service.

Thread x Thread End Connections							
Nominal Valve Sizes Inches (DN)	Nominal Installation Dimensions in. (mm)						Approx. Weight lb (kg)
	A	B	C	D	E	F	
2 (50)	7.51 (191)	1.34 (34)	7.32 (186)	6.41 (163)	8.18 (208)	1.34 (34)	16.5 (7,5)
3 (80)	11.42 (290)	1.97 (50)	8.19 (208)	7.48 (190)	9.25 (235)	1.97 (50)	30.6 (13,9)

Groove x Groove End Connections							
Nominal Valve Sizes Inches (DN)	Nominal Installation Dimensions in. (mm)						Approx. Weight lb (kg)
	A	B	C	D	E	F	
2 (50)	7.71 (196)	1.18 (30)	7.32 (186)	6.41 (163)	8.18 (208)	1.18 (30)	15.2 (6,9)
3 (80)	11.42 (290)	1.77 (45)	8.19 (208)	7.48 (190)	9.25 (235)	1.77 (45)	30.6 (13,9)
4 (100)	13.62 (346)	2.24 (57)	8.70 (221)	7.91 (201)	9.68 (246)	2.24 (57)	40.6 (18,4)
6 (150)	17.80 (452)	3.30 (84)	9.88 (251)	6.73 (171)	11.49 (292)	3.30 (84)	75.6 (34,3)
8 (200)	18.50 (470)	6.30 (160)	11.14 (283)	9.25 (235)	12.55 (319)	6.69 (170)	110.0 (49,9)

Flange x Flange End Connections							
Nominal Valve Sizes Inches (DN)	Nominal Installation Dimensions in. (mm)						Approx. Weight lb (kg)
	A	B	C	D	E	F	
3 (80)	11.14 (283)	3.93 (100)	8.19 (208)	7.48 (190)	9.25 (235)	3.93 (100)	46.3 (21,0)
4 (100)	12.00 (305)	4.37 (111)	8.70 (221)	7.91 (201)	9.68 (246)	4.37 (111)	57.3 (26,0)
6 (150)	15.98 (406)	5.59 (142)	9.88 (251)	6.73 (171)	11.49 (292)	5.60 (142)	112.4 (51,0)
8 (200)	18.50 (470)	6.30 (160)	11.14 (283)	7.16 (182)	12.55 (319)	6.69 (170)	149.9 (68,0)

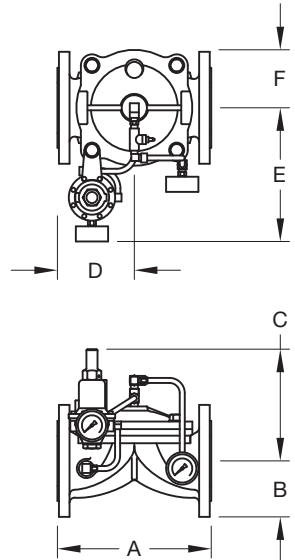

FIGURE 5
MODEL PRV-1 PRESSURE REDUCING VALVE
GLOVE STYLE INSTALLATION DIMENSIONS

Thread x Thread End Connections							
Nominal Valve Sizes Inches (DN)	Nominal Installation Dimensions in. (mm)						Approx. Weight lb (kg)
	A	B	C	D	E	F	
2 (50)	3.62 (92)	3.23 (83)	7.32 (186)	6.41 (163)	8.18 (208)	2.40 (61)	16.5 (7,5)
3 (80)	5.91 (150)	4.21 (107)	8.19 (208)	7.48 (190)	9.25 (235)	3.93 (100)	30.6 (13,9)

Groove x Groove End Connections							
Nominal Valve Sizes Inches (DN)	Nominal Installation Dimensions in. (mm)						Approx. Weight lb (kg)
	A	B	C	D	E	F	
2 (50)	3.62 (92)	3.23 (83)	7.32 (186)	6.41 (163)	8.18 (208)	2.40 (61)	15.2 (6,9)
3 (80)	5.91 (150)	4.21 (107)	8.19 (208)	7.48 (190)	9.25 (235)	3.93 (100)	33.5 (15,2)
4 (100)	6.42 (163)	4.57 (116)	8.70 (221)	7.91 (201)	9.68 (246)	4.52 (115)	42.8 (19,4)
6 (150)	8.9 (226)	6.69 (170)	9.88 (251)	6.73 (171)	11.49 (292)	5.90 (150)	83.8 (38,0)

Flange x Flange End Connections							
Nominal Valve Sizes Inches (DN)	Nominal Installation Dimensions in. (mm)						Approx. Weight lb (kg)
	A	B	C	D	E	F	
3 (80)	6.26 (159)	4.53 (115)	8.19 (208)	7.48 (190)	9.25 (235)	3.93 (100)	48.5 (22)
4 (100)	6.85 (174)	4.65 (118)	8.70 (221)	7.91 (201)	9.68 (246)	4.52 (115)	61.1 (27,7)
6 (150)	7.99 (203)	5.83 (148)	9.88 (251)	6.73 (171)	11.49 (292)	5.90 (150)	110.2 (50)

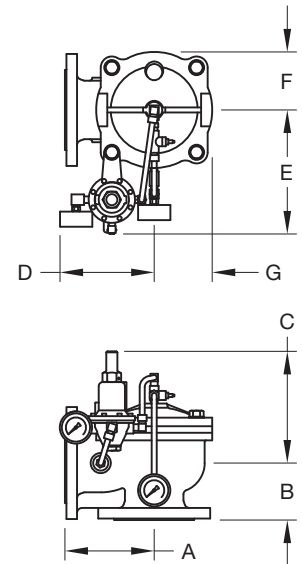
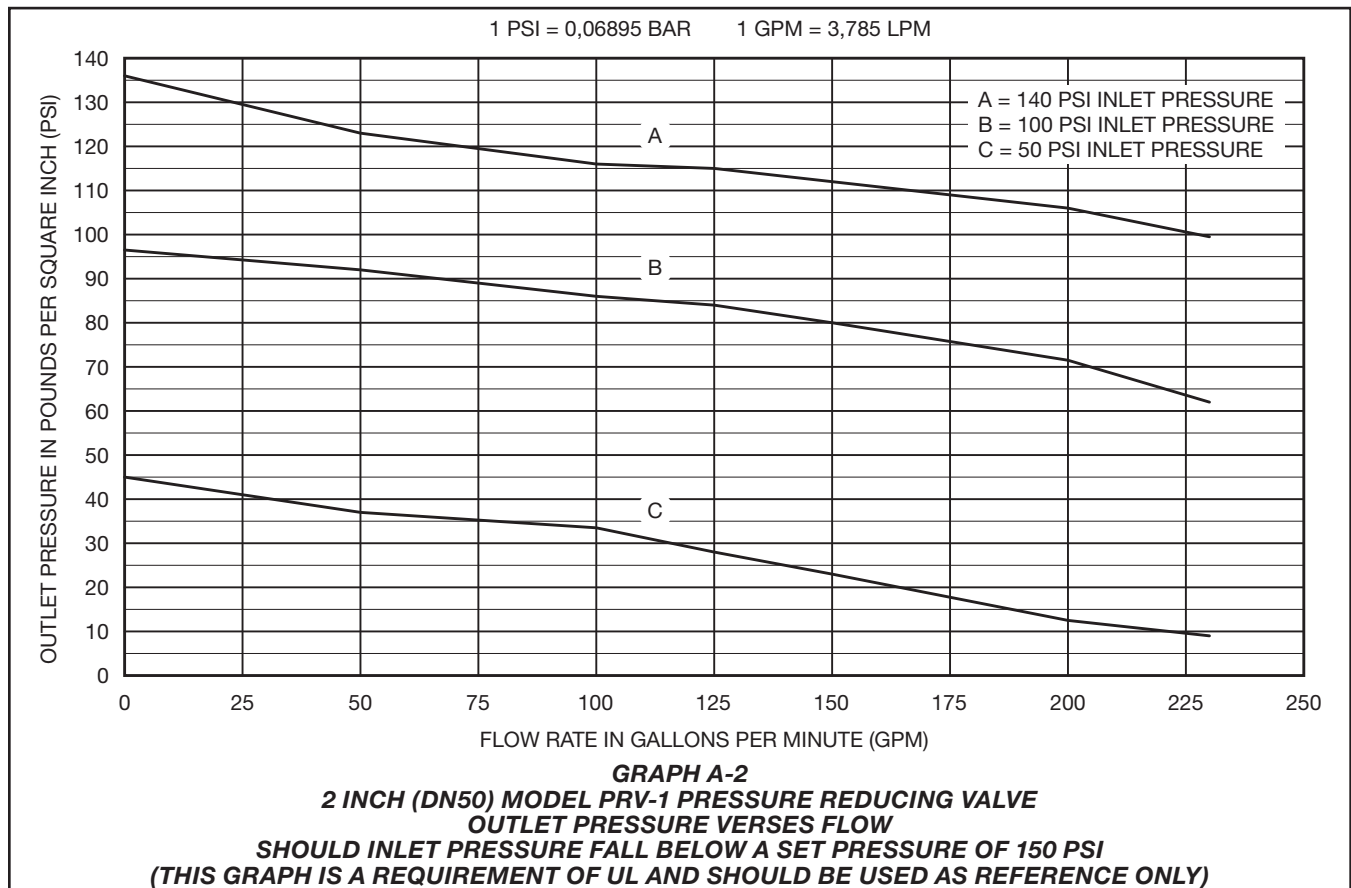
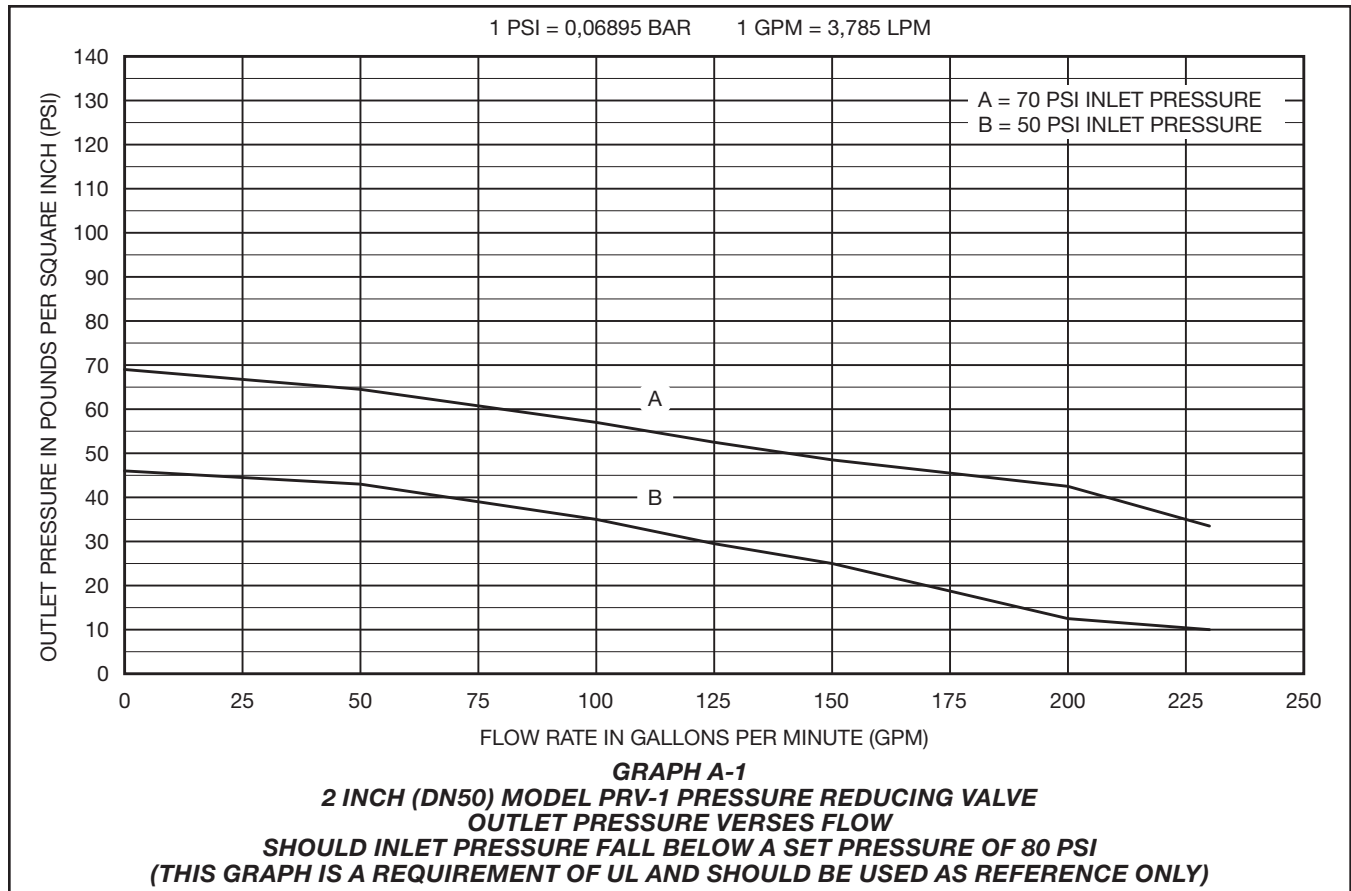
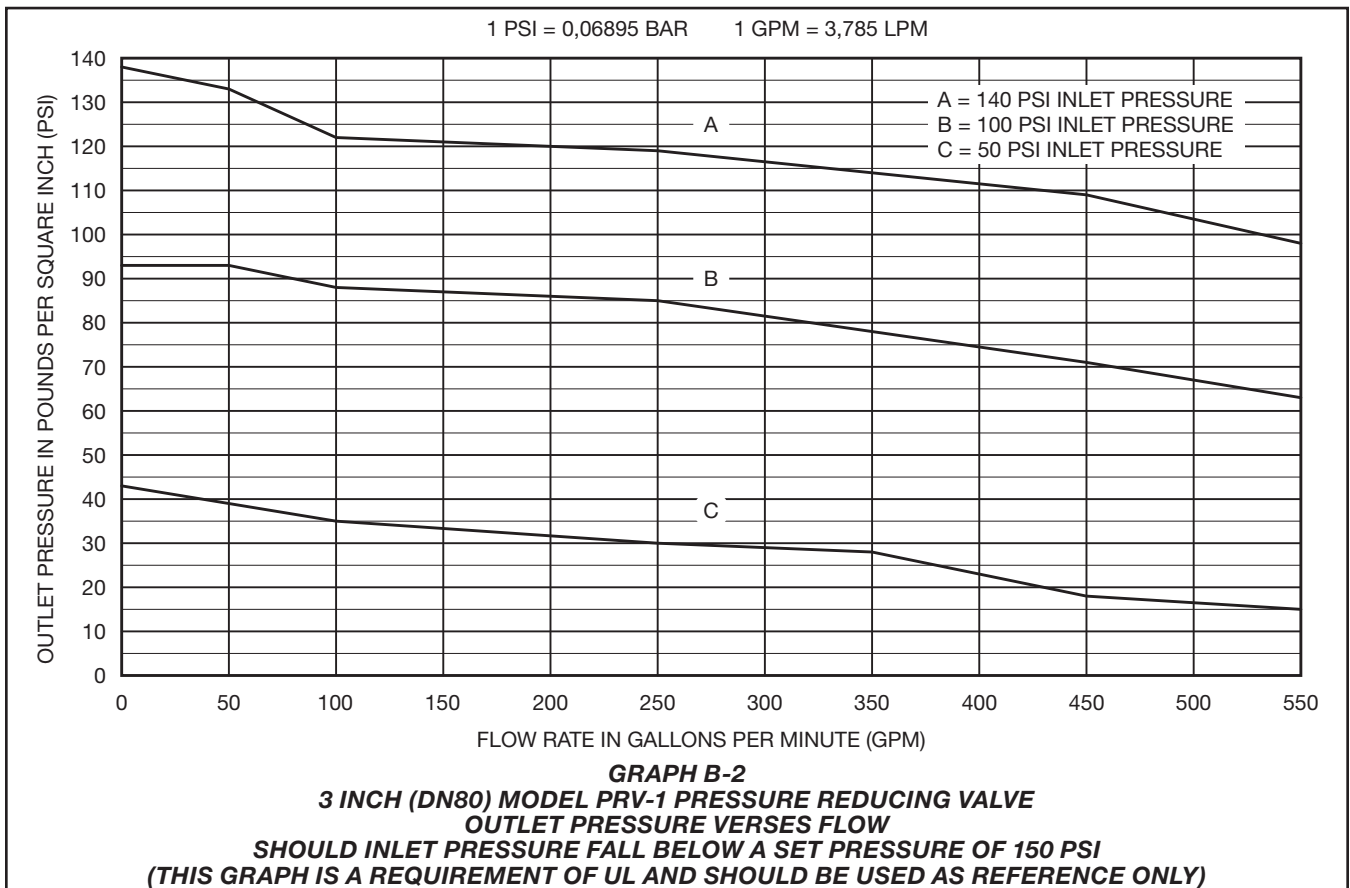
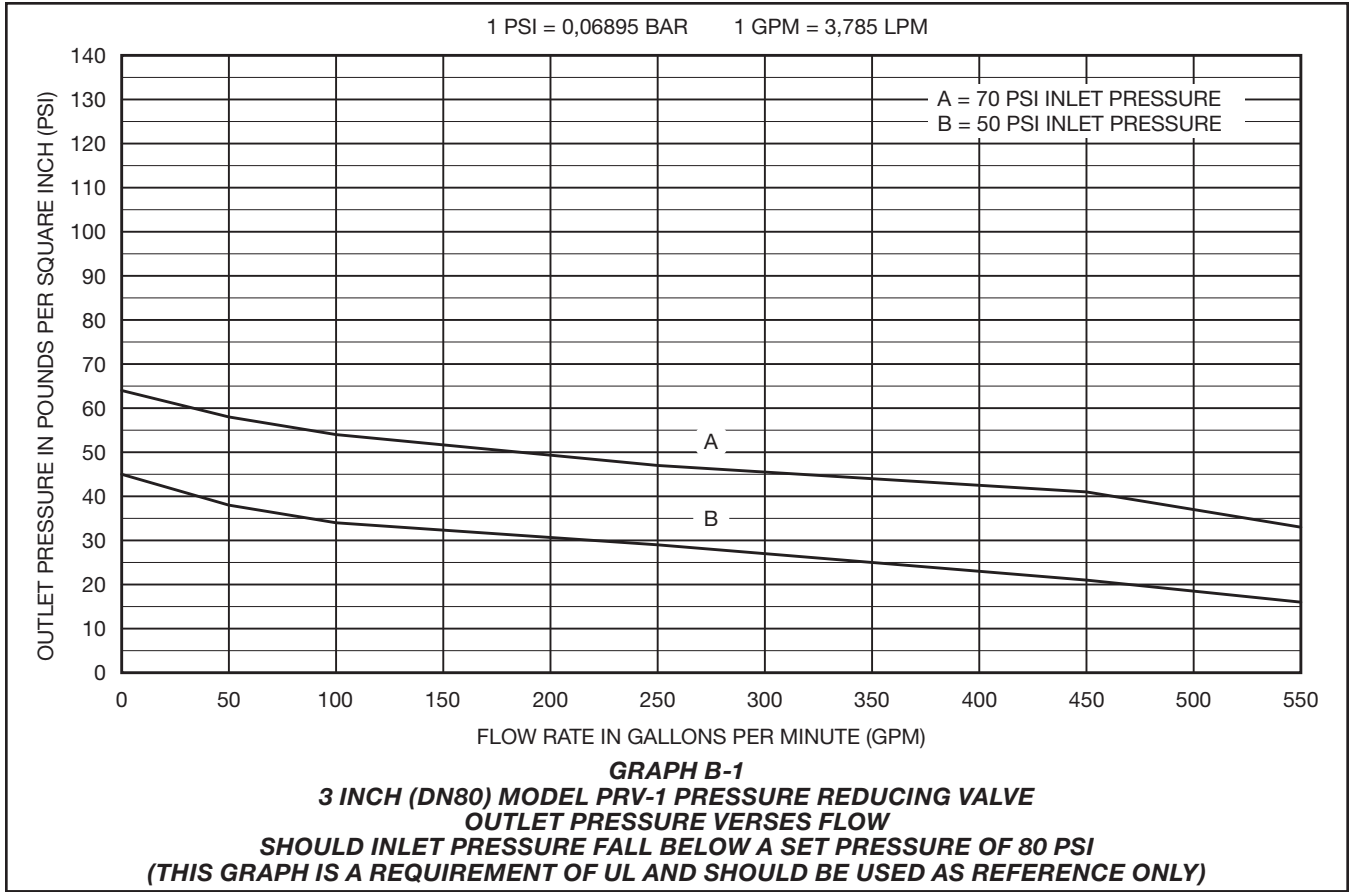
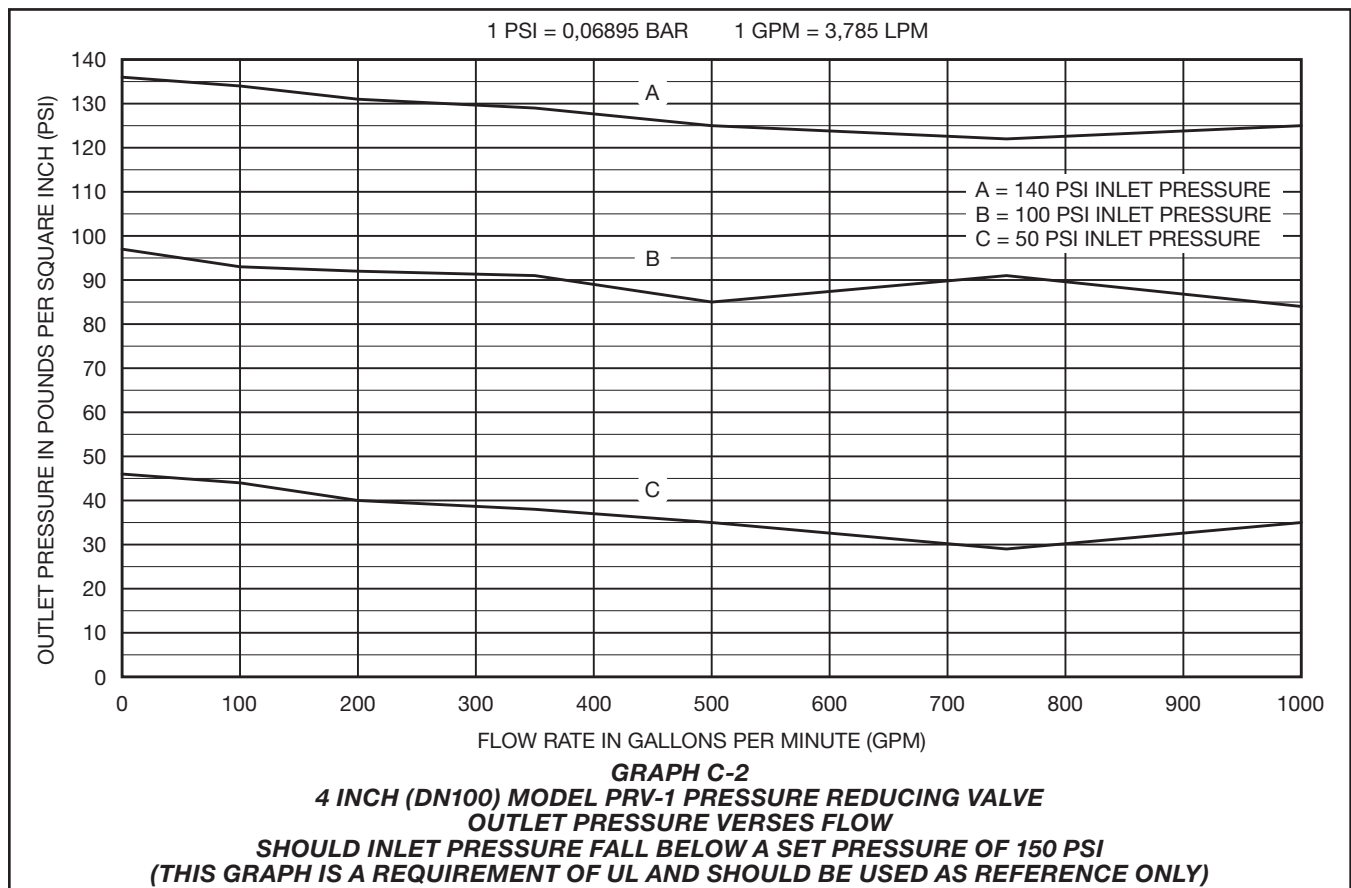
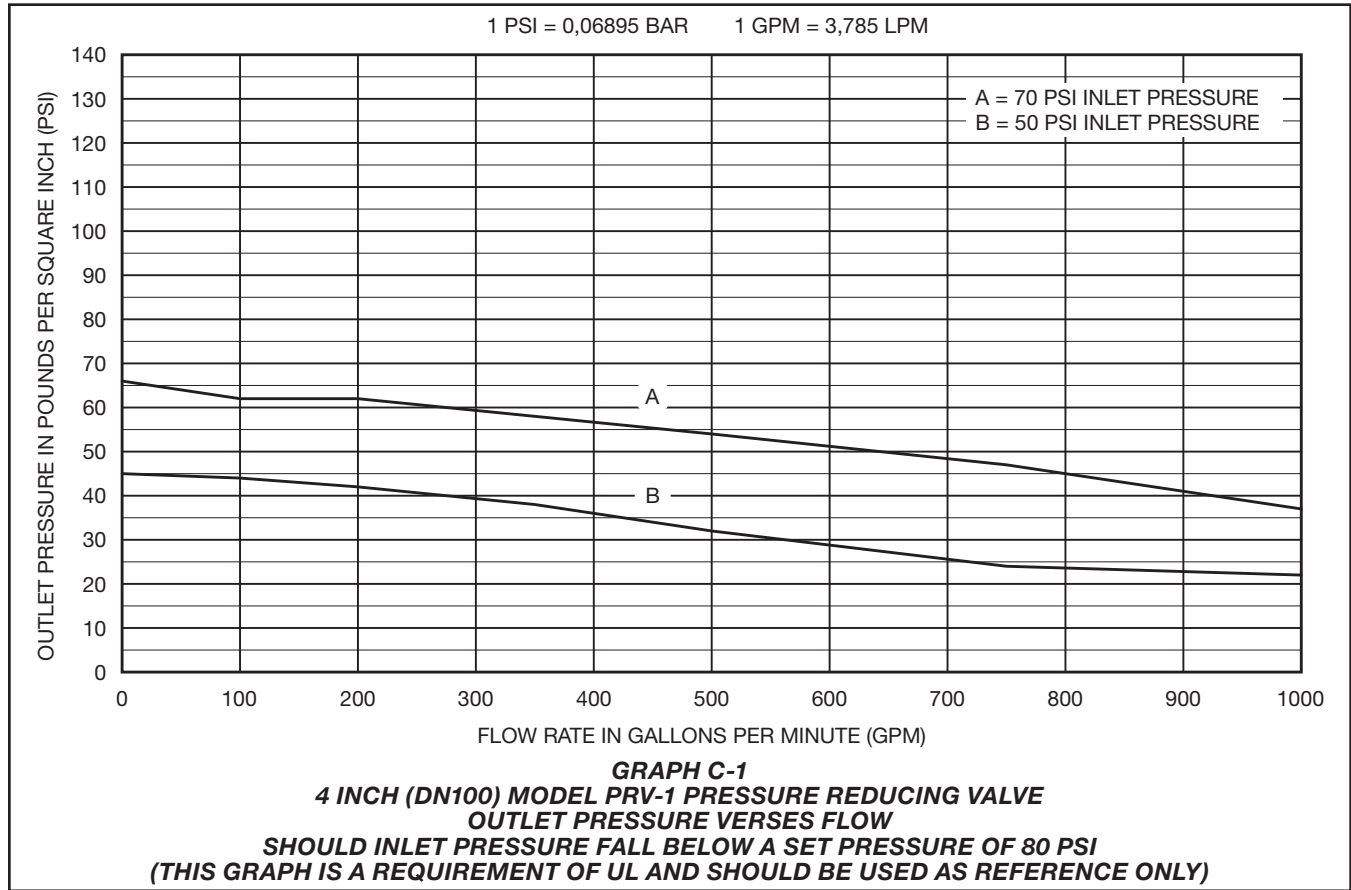
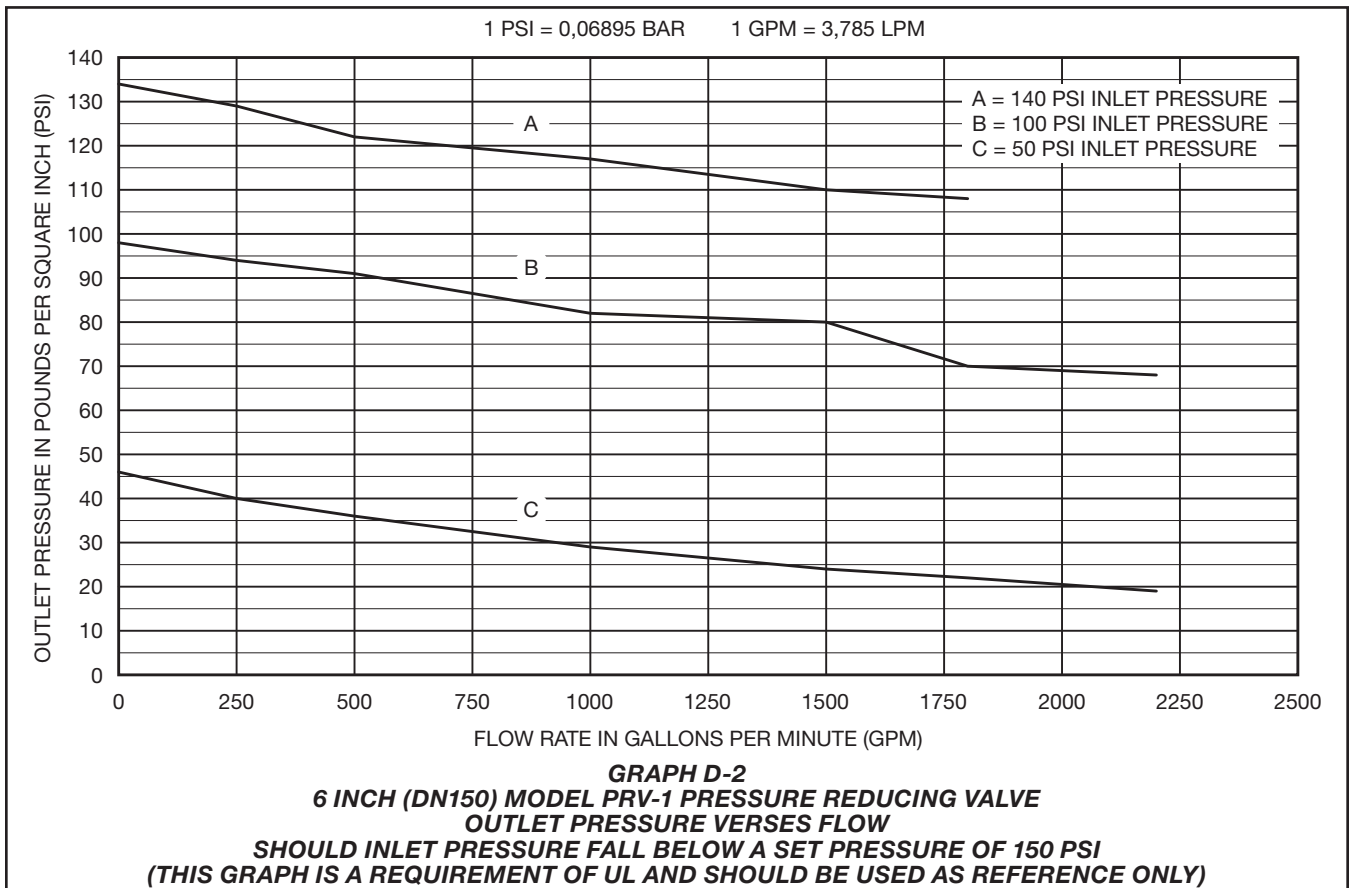
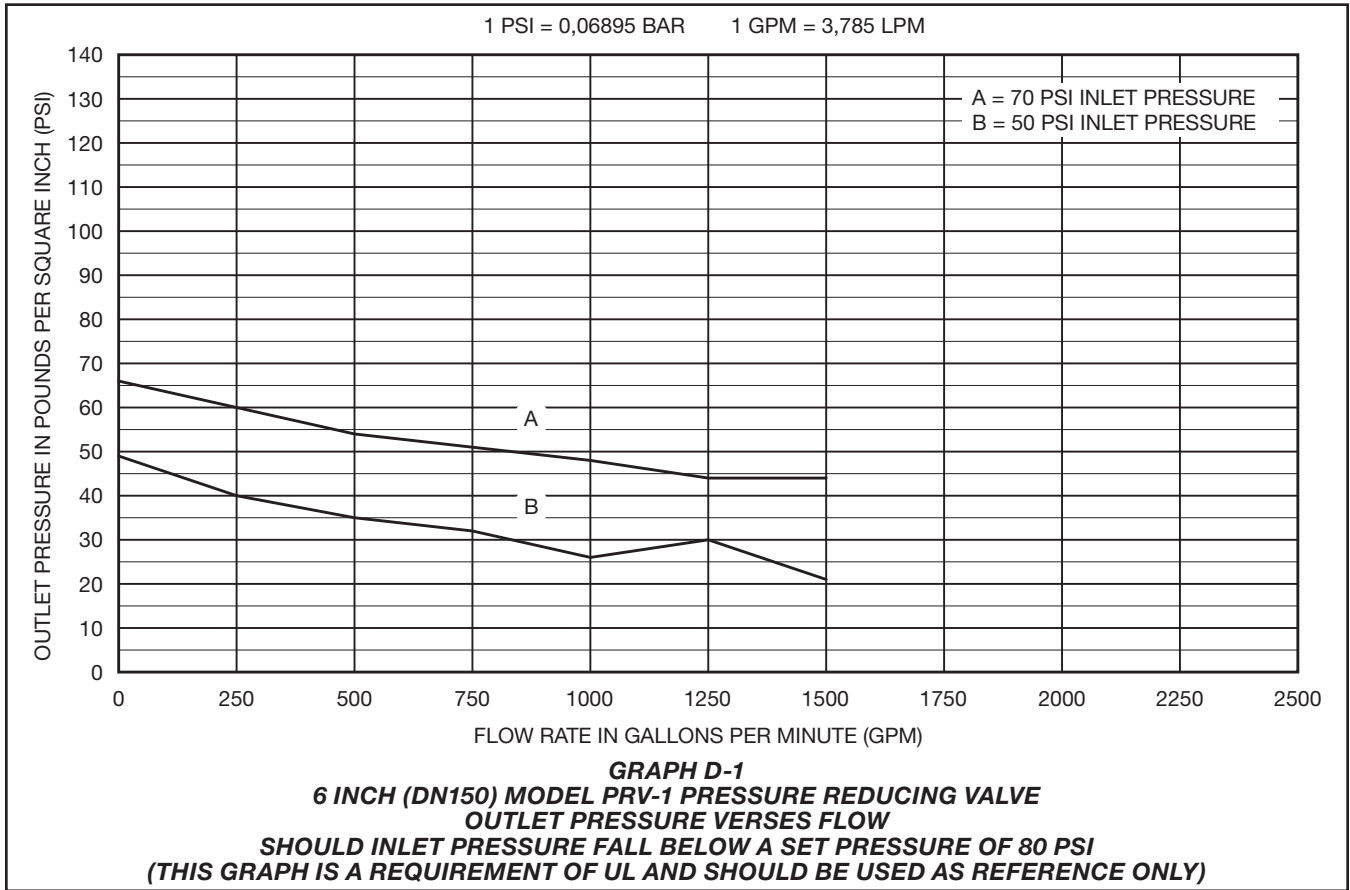

FIGURE 6
MODEL PRV-1 PRESSURE REDUCING VALVE
ANGLE STYLE INSTALLATION DIMENSIONS









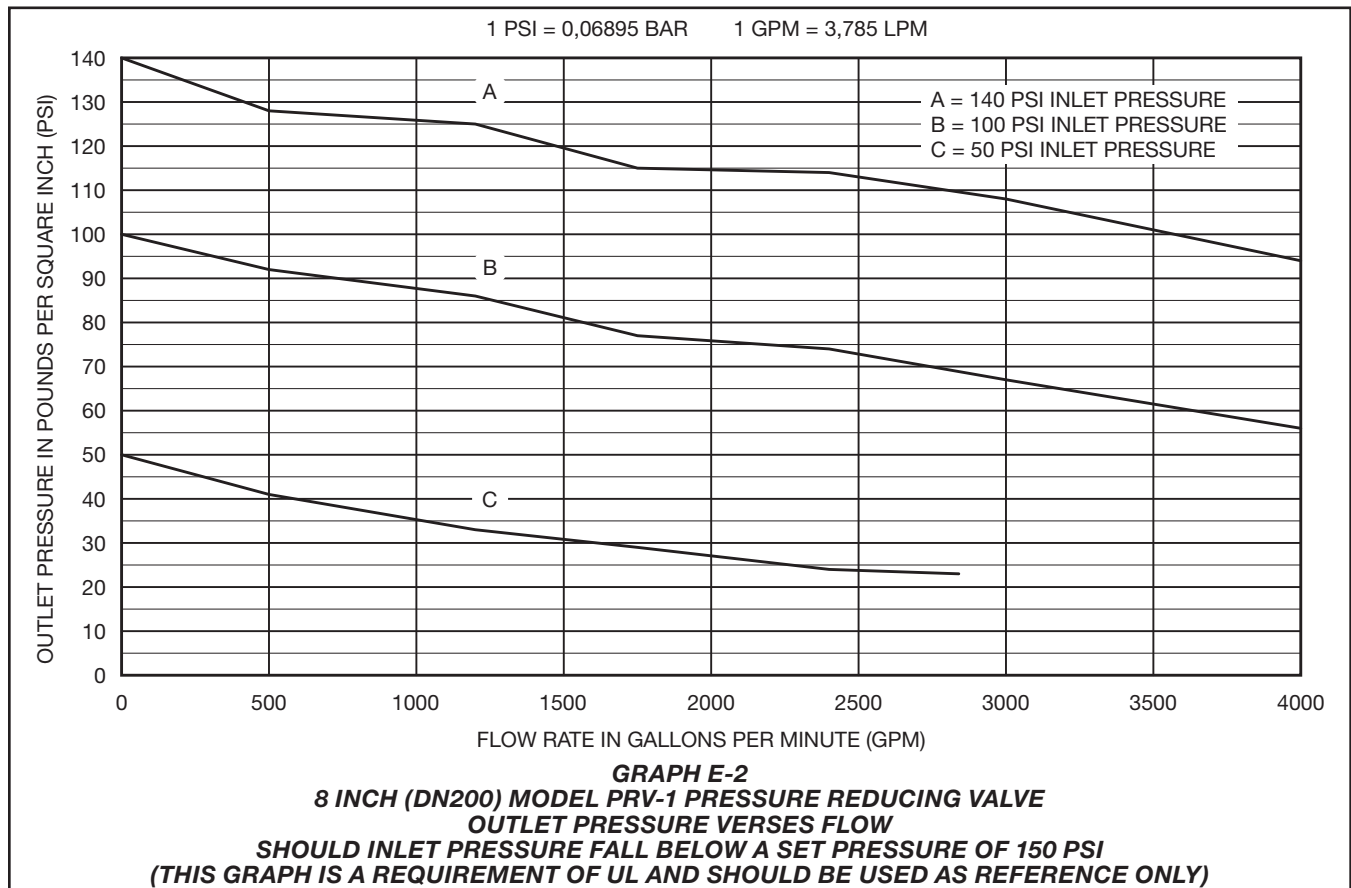
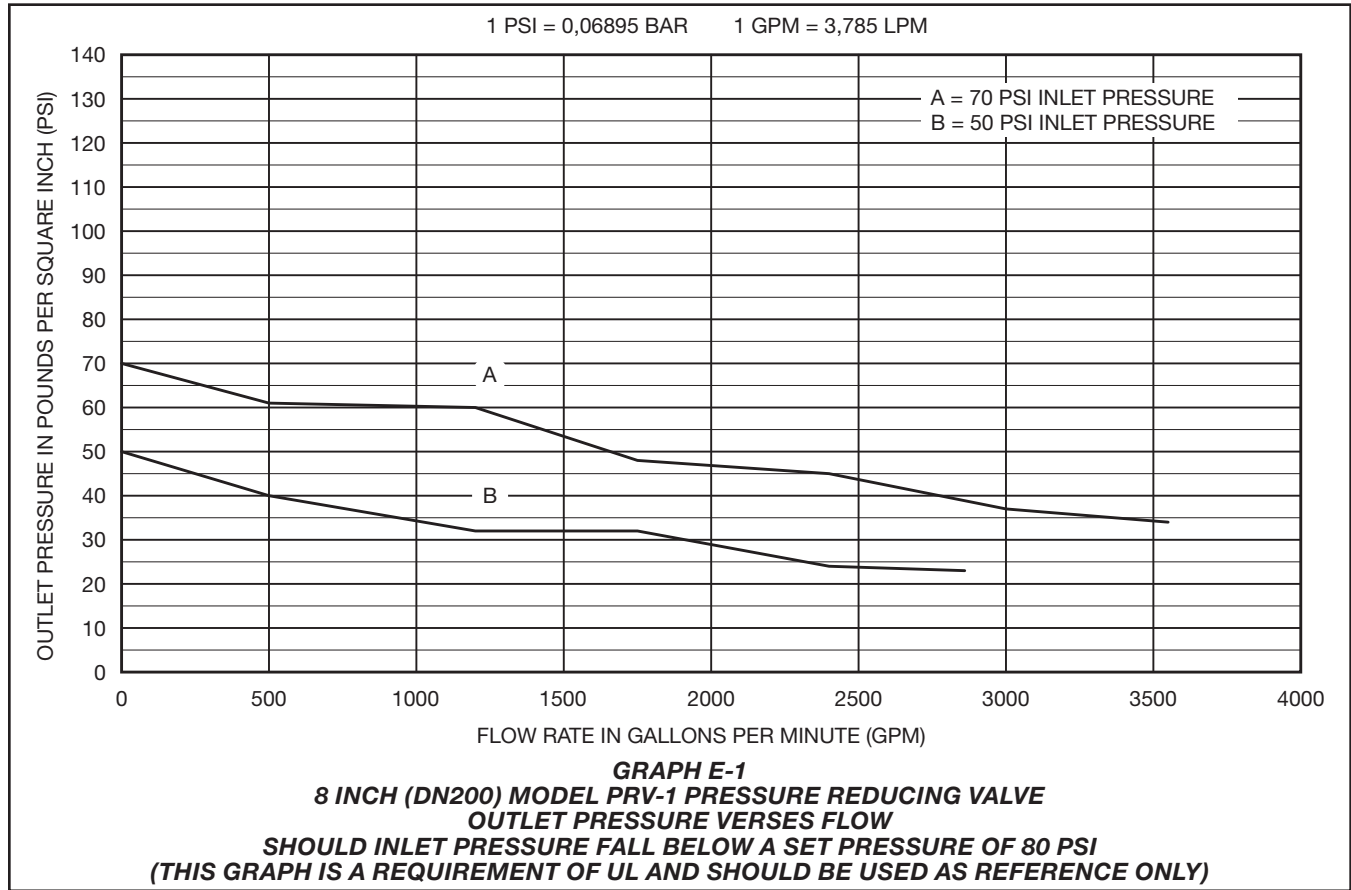

Limited Warranty

For warranty terms and conditions, visit
www.tyco-fire.com.

Ordering Procedure

North America Pressure Reducing Valve

Specify: Globe Type, (specify size), 125 psi (8,6 bar) Outlet “Set Pressure” with (T x T, G x G, or F x F) Connection, P/N (specify from below).

2 in. T x T NPT	52-570-8-060
2 in. G x G 2.37 in. (60,3 mm) Groove O.D.	52-570-8-920
3 in. G x G 3.50 in. (88,9 mm) Groove O.D.	52-570-8-922
4 in. G x G 4.50 in. (114,3 mm) Groove O.D.	52-570-8-923
4 in. F x F ANSI Flange	52-570-8-023
6 in. G x G 6.62 in. (168,3 mm) Groove O.D.	52-570-8-925
6 in. F x F ANSI Flange.	52-570-8-025
8 in. G x G 8.62 in. (219,1mm) Groove O.D.	52-570-8-926
8 in. F x F ANSI Flange	52-570-8-026

Pressure Relief Valve
Specify: 1/2 in. (DN15) Watts Regulator, Series 530C Pressure Relief Valve for use downstream of a Model PRV-1 Valve being used for reducing pressure in sprinkler system, P/N 20608

Replacement Valve Parts
Specify: (description) for use with (specify) size Model PRV-1 Pressure Reducing Valve, P/N (see Figure 3)

**South America, Central America and Eastern Hemisphere
Pressure Reducing Valve**
Specify: (Globe or Angle) Type, (specify size), 125 psi (8,6 bar) Outlet “Set Pressure” with (specify) Connection (and for flanged valves specify flange drilling), P/N (specify from complete listing on Page 16).

- Valve Type and Size
Globe, 2, 3, 4, 6, or 8 in.
Angle, 2, 3, 4, or 6 in.
- 125 psi (8,6 bar) Outlet “Set Pressure” Pressure
- Connection Type (Threaded, Grooved, Flanged)
For threaded, specify NPT or ISO
For grooved, specify O.D. Pipe Size
2 in. (DN50) 2.88 in. (60,3 mm) O.D.
3 in. (DN80) 3.50 in. (88,9 mm) O.D.
4 in. (DN100) 4.50 in. (114,3 mm) O.D.
6 in. (DN150) 6.62 in. (168,3 mm) O.D.
or 6.50 in. (165,1 mm) O.D.
8 in. (DN200) 8.62 in. (219,1 mm) O.D.
- For flanged, specify flange drilling per
ANSI B16-1 (Class 125)
ISO 7005-2 (PN16)
ISO 7005-2 (PN10), 8 in. valve only
JIS B2210 (10K)
AS 2129 (Table E)

Note: Refer to Table C for flange drilling dimensional specifications.

Globe Body Style

2 in. T x T NPT	52-570-8-060
2 in. T x T ISO	52-570-8-160
2 in. G x G 2.37 in. (60,3 mm) Groove O.D.	52-570-8-920
3 in. T x T NPT	52-570-8-062
3 in. T x T ISO	52-570-8-162
3 in. G x G 3.50 in. (88,9 mm) Groove O.D.	52-570-8-922
3 in. F x F ANSI Flange	52-570-8-022
3 in. F x F ISO (PN16) Flange	52-570-8-112
3 in. F x F JIS Flange	52-570-8-722
3 in. F x F AS Flange	52-570-8-522
4 in. G x G 4.50 in. (114,3 mm) Groove O.D.	52-570-8-923
4 in. F x F ANSI Flange	52-570-8-023
4 in. F x F ISO (PN16) Flange	52-570-8-113
4 in. F x F JIS Flange	52-570-8-723
4 in. F x F AS Flange	52-570-8-523
6 in. G x G 6.62 in. (168,3 mm) Groove O.D.	52-570-8-925
6 in. G x G 6.50 in. (165,1 mm) Groove O.D.	52-570-8-945
6 in. F x F ANSI Flange	52-570-8-025
6 in. F x F ISO (PN16) Flange	52-570-8-115
6 in. F x F JIS Flange	52-570-8-725
6 in. F x F AS Flange	52-570-8-525
8 in. G x G 8.62 in. (219,1mm) Groove O.D.	52-570-8-926
8 in. F x F ANSI Flange	52-570-8-026
8 in. F x F ISO (PN10) Flange	52-570-8-116
8 in. F x F ISO (PN16) Flange	52-570-8-126
8 in. F x F JIS Flange	52-570-8-726
8 in. F x F AS Flange	52-570-8-526

Angle Body Style

2 in. T x T	
NPT	52-571-8-060
2 in. T x T	
ISO	52-571-8-160
2 in. G x G	
2.37 in. (60,3 mm)	
Groove O.D.	52-571-8-920
3 in. T x T	
NPT	52-571-8-062
3 in. T x T	
ISO	52-571-8-162
3 in. G x G	
3.50 in. (88,9 mm)	
Groove O.D.	52-571-8-922
3 in. F x F	
ANSI Flange	52-571-8-022
3 in. F x F	
ISO (PN16) Flange	52-571-8-112
3 in. F x F	
JIS Flange	52-571-8-722
3 in. F x F	
AS Flange	52-571-8-522
4 in. G x G	
4.50 in. (114,3 mm)	
Groove O.D.	52-571-8-923
4 in. F x F	
ANSI Flange	52-571-8-023
4 in. F x F	
ISO (PN16) Flange	52-571-8-113
4 in. F x F	
JIS Flange	52-571-8-723
4 in. F x F	
AS Flange	52-571-8-523
6 in. G x G	
6.62 in. (168,3 mm)	
Groove O.D.	52-571-8-925
6 in. G x G	
6.50 in. (165,1 mm)	
Groove O.D.	52-571-8-945
6 in. F x F	
ANSI Flange	52-571-8-025
6 in. F x F	
ISO (PN16) Flange	52-571-8-115
6 in. F x F	
JIS Flange	52-571-8-725
6 in. F x F	
AS Flange	52-571-8-525

Pressure Relief Valve

Specify: Size (specify) Watts Regulator, Series 530C Pressure Relief Valve for use downstream of a Model PRV-1 Valve being used for reducing pressure in sprinkler system, P/N (Specify):

South America and Central America	
1/2 in. (DN15)	20608
Eastern Hemisphere	
1/2 in. (DN15)	92-570-2-208

Replacement Valve Parts

Specify: (description) for use with (specify) size Model PRV-1 Pressure Reducing Valve, P/N (see Figure 3)